

KX110
SILICON CRYSTAL
GROWING FURNACE



Maximizing silicon output

Minimizing cost

20-inch hot zone capability

Performance

Typical Ingot Diameter	150-200 mm (6-8")
Pull Chamber Height	2000 mm (79")
Throat Diameter	305 mm (12")
Furnace Diameter	900 mm
Seed Lift Rate	0-508 mm/hr
Seed Jog Speed (Nominal)	508 mm/min
Total Crucible Travel	380 mm (15")
Crucible Lift Rate	0-254 mm/hr
Crucible Jog Speed (Nominal)	50.8 mm/min
Seed Rotation (Reversible)	0-50 rpm
Crucible Rotation (Reversible)	0-20 rpm
Vacuum Pumps Main	5660 l/min (200 cfm)
(Min. recommended) Aux	990 l/min (35 cfm)

Utility Requirements

ELECTRICAL:	
FURNACE	190 kVA, 380 / 400 / 440 / 460 ±10% VAC 3 Ø 50/60 Hz, fused for 375 / 350 / 325 / 300 A
COOLANT WATER:	
Maximum Inlet Temperature	25°C (77°F)
Minimum Flow Rate	190 l/min (50 gpm) total
Diff. Supply Pressure	38 psi (2.7kg/cm ²)
ARGON:	
Mass Flow Control (Max.)	100 slpm
Purge Flow	75 slpm
Facility Total	175 slpm
Recommended Supply Pressure	5.2 bar (75 psi)
AIR:	
Recommended Supply Pressure	6.2 bar (90 psi)

Dimensions

	Furnace Overall	Control Console	Power Supply
HEIGHT	6.26m (247 in)	1.60 m (63 in)	0.98 m (39 in)
WIDTH	2.90 m (114 in)	0.66 m (26 in)	0.77 m (31 in)
DEPTH	2.76 m (109 in)	0.91 m (36 in)	1.12 m (44 in)
WEIGHT	5,000 kg	(11,000 lb)	

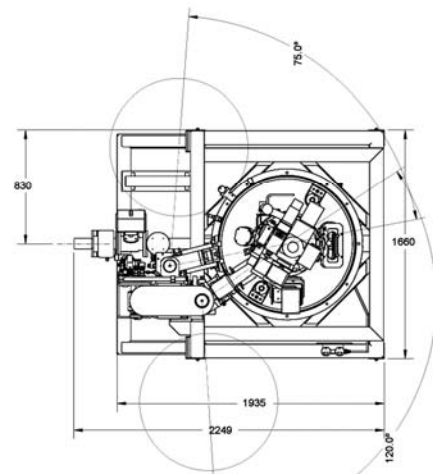
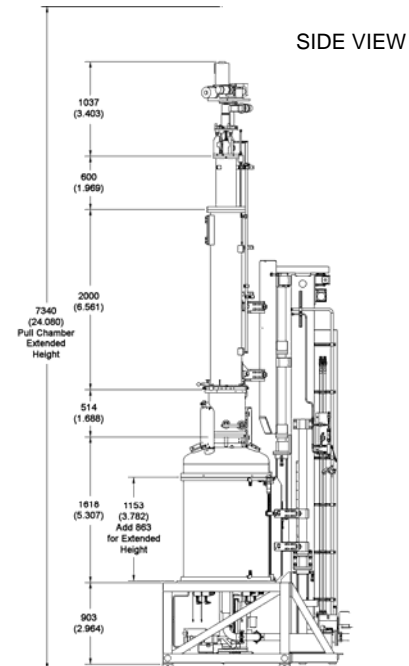

PLAN VIEW CHAMBERS OPEN

Silicon Charge Capacity

Hot zones are available to fit the following crucible sizes. Charges can be enhanced with a feeder.			
Crucible Diameter	Crucible Height	Charge Size Cold Pack	Enhanced Charge
20.0 in	16.33 in	100 kg	125 kg

KAYEX, AN SPX DIVISION

1000 Millstead Way, Rochester, NY 14624 USA • Tel +1 (585) 235-2524 • Fax +1 (585) 436-2396 •
www.kayex.com / www.kayex.cn

ALL SPECIFICATIONS ARE FOR REFERENCE ONLY AND ARE SUBJECT TO CHANGE WITHOUT NOTICE.